

CTD DOSING SYSTEM



TYPE

- CTD - 40.1
- CTD - 75.1
- CTD - 100.1
- CTD - 200.1
- CTD - 300.1
- CTD - 500.1
- CTD - 1000.1

i NOTE

Keep the operating manual for future use!

! ATTENTION

Subject to technical modifications!

Technical manuals of the system subassemblies

! WARNUNG

The operating instructions of the system components in the overall documentation must be observed!
The revision of the overall documentation given in these instructions must be observed!

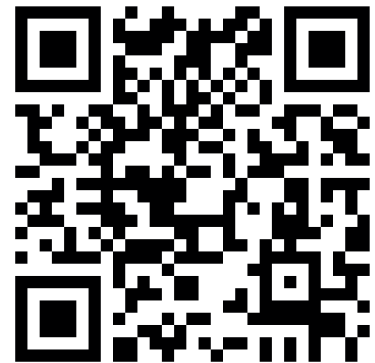

DOWNLOAD

Download the technical manuals of the system subassemblies.

Or directly scan the QR code opposite:

REVISION 02

Quality notes

The **sera** quality management and quality assurance system is certified in accordance with DIN EN ISO 9001:2015. The **sera** product complies with the applicable safety requirements and accident prevention regulations.

About this instructions

Special notes in these instructions are marked with text and danger symbols.

NOTE

Notes or instructions that facilitate work and ensure a safe operation.

ATTENTION

The non-observance of these safety instructions can result in malfunctions or material damages.

WARNING

The non-observance of these safety instructions can lead to material damages and personal injuries.



Note on the additional instructions „SAFETY INSTRUCTIONS SI02.

These technical manual is divided into the following main parts:

TRANSPORT & STORAGE	page 6
PRODUCT DESCRIPTION	page 7
TECHNICAL DATA	page 19
ASSEMBLY / INSTALLATION	page 21
COMMISSIONING	page 23
MAINTENANCE	page 24
SHUT-DOWN / DISPOSAL	page 25
CLEARANCE CERTIFICATE	page 2

TRANSPORT & STORAGE	6
General	6
Storage.....	6
Transport	6
PRODUCT DESCRIPTION	7
Type key	7
Type plate	7
Notes attached to the product.....	7
Materials	7
Water quality	7
Gas-tight design (Pos. 40)	10
Dosing pump (Pos. 100)	10
Multifunction valve (Pos. 150).....	10
Level indication (Pos. 200/220/240).....	11
Filling valve (Pos. 300)	13
Container threaded joint (Pos. 350)	13
Drain cock or PE collecting basin (Pos. 400).....	13
Agitator (Pos. 500).....	14
Level indicator for black tank (Pos. 600)	14
Cabling (Pos. 700).....	14
Control unit (Pos. 800).....	14
Accessories	15
Dissolving basket (non gas-tight)	15
Terminal boxes and electrical connection sets	15
Splash guard.....	16
Dosing equipment DE	16
TECHNICAL DATA	19
ASSIGNMENT OF PUMPS	19
NOISE MEASUREMENT	19
VISCOSITY	19
TEMPERATURE DATA	19
AMBIENT CONDITIONS	19
ASSEMBLY / INSTALLATION	21
Place of installation	21
Electrical connection.....	22
COMMISSIONING	23
MAINTENANCE	24
Wearing parts	24
SHUT-DOWN / DISPOSAL	25
Decommissioning	25
Disposal.....	25
CLEARANCE CERTIFICATE	26

WARNING

Observe and follow the safety instructions by all means.
See the additional instructions „SAFETY INSTRUCTIONS“.
Man, machine and environment are endangered if the safety instructions are not observed.



General

sera products are checked for perfect condition and function previous to shipment.
Check for transport damage immediately after arrival of goods. If damage is found, this is to be reported immediately to the responsible carrier and the manufacturer.

Storage

An undamaged packaging protects the unit during storage and should only be opened when the product is installed.
Proper storage increases the service life of the product and includes prevention of negative influences such as heat, moisture, dust, chemicals etc.

The following storage specifications are to be observed:

- Storage place: cool, dry, dustfree and slightly ventilated
- Storage temperature and relative air humidity see Chapter „TECHNICAL DATA“.
- The maximum storage time for the standard packaging is 12 months.

If these values are exceeded, metal products should be sealed in foil and protected from condensation water with a suitable desiccant.

Do not store solvents, fuels, lubricants, chemicals, acids, disinfectants and similar in the storage room.

Transport

The unit should only be transported using suitable lifting gears. Take into account the weight of the unit and the load-bearing capacity of the means of transport.

The transport is carried out standing up.

Example:

Lifting using a pallet (from size CTD-200 included in the scope of supply).
Lead the carrying belts underneath the pallet from four sides and lift.

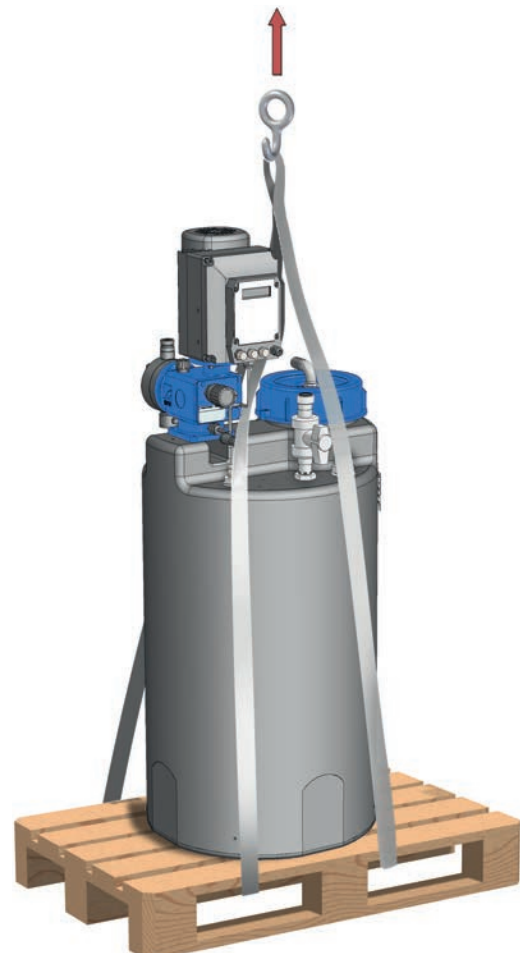

ATTENTION

Be careful when lifting the dosing station. Pay attention to the center of gravity!
Fasten the dosing station sufficiently!

ATTENTION

Be careful when lifting the dosing station. Ensure that the tank superstructures don't get damaged by the tension belts. Never hang the dosing station at the tank superstructures (e.g. pump/electric agitator).

ATTENTION

Never lay the dosing station on its sides. Pay attention to the weight of the dosing station and lift it with two or three persons.

Type key

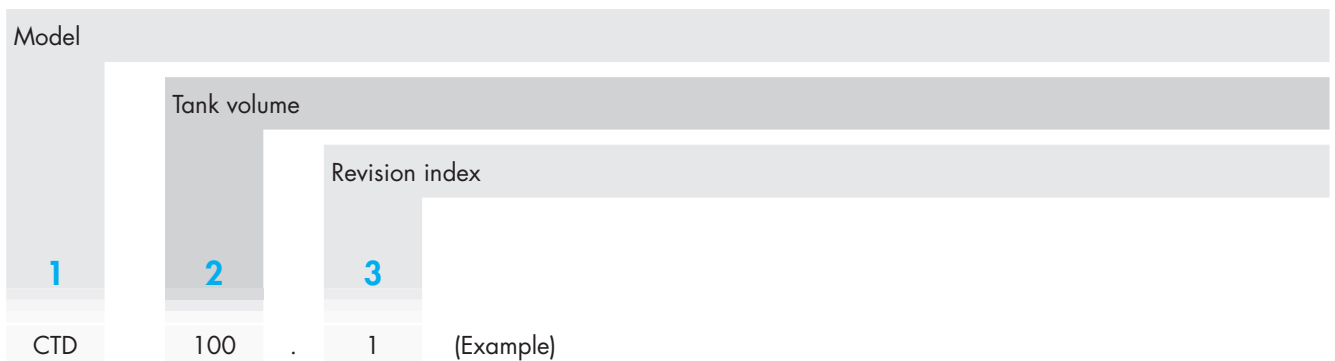

Type plate

Each **sera** system is factory provided with a type plate. The following information can be found on this type plate.



No.	Designation
1	Type of system
2	Serial-no. of system
3	Year of construction
4	Medium

Notes attached to the product

Symbols which are directly attached to the pump, e.g. arrows for direction of rotation or symbols for fluid connections are to be observed and kept in legible condition.

Materials

The materials used are stated in the order confirmation and the product description.

Water quality



ATTENTION

Water used for start-up, maintenance and closing down must be similar to drinking water, i.e. chemically neutral, free from solid and suspended matters and disturbing ion concentrations.
 Note the compatibility of the chemical with water and take appropriate measures, if necessary.
 Pay attention to the safety data sheet of the medium.

PRODUCT DESCRIPTION

The basic unit consists of a PE tank with litre scale and screw cap. The dosing station is screwed onto the floor with four angle brackets. Aeration and ventilation of the tank is ensured by an aeration and vent pipe bend on the screw cap. The medium is removed by a suction lance.

The tanks are of natural polyethylene as standard. The material is milky transparent. The tank can also be black if light-sensitive media are used.

The detailed design of the system is stated in the product description.

The basic unit and the options available for the dosing station are shown on the following figure:

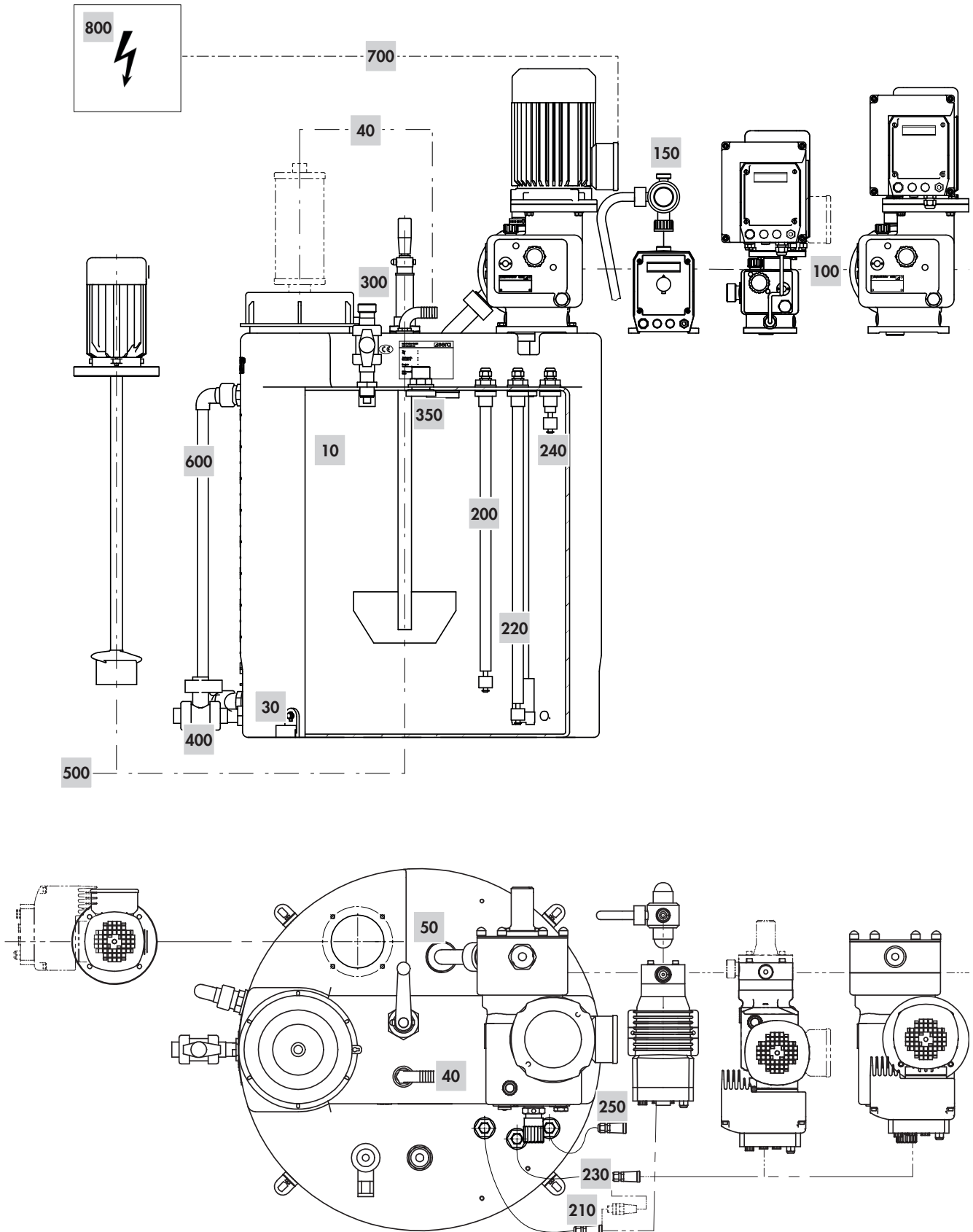

No.	Designation	Remark
10	PE tank with litre scale and screw cap DN162	
30	4x fixing bracket	
40	Aeration and deaeration pipe bend	
40	Gas-tight design – connection to the ventilation system (DN15 or DN25) or chemical gas absorber (up to 1500l/h)	Option
50	Suction lance with foot valve and sieve	
100	Dosing pump	Option
150	Multifunction valve (up to 50l/h) with return pipe in the tank	Option
200	Solenoid float switch, prealarm LSL (min)	Option
210	Cable socket M12 for LSL level or LSL connection to the controllable pump	Option
220	Solenoid float switch, dry-run protection LSL (min-min)	Option
230	Cable socket M12 for LSL level or LSL connection to the controllable pump	Option
240	Solenoid float switch, full level indication LSH (max)	Option
250	Cable socket M12 for LSH level	Option
300	Filling valve with ball cock (DN15 – G1 or DN25 – G1 1/2)	Option
350	Container threaded joint (DN15 – G1)	Option
400	Drain cock with ball cock DN15 or PE collecting basin	Option
500	Agitator	Option
600	Level indicator for black tank, PVC-transparent	Option
700	Cabling	Option
800	Control unit	Option
not represented	End connection of suction lance: DN 5 - G 3/4 female thread with 2m PE hose, DN 10 - G 3/4 male thread, DN 15 - G1 male thread	
not represented	Integrated overflow valve at the pump with return pipe in the tank	Option
not represented	Protective roof for drive motor of the pump	Option

 **WARNING**

The operating instructions of the system components in the overall documentation must be observed!

PRODUCT DESCRIPTION

Gas-tight design (Pos. 40)

The aeration and deaeration pipe bend on the screw cap can be replaced with a connection to the ventilation system (DN15 or DN25). The tank is connected with a hose (inside diameter 20mm or 30mm) to the on-site ventilation system.

ATTENTION

The tank may only be operated when it is not under pressure. The hose connection for aeration and ventilation must not be clogged or used for other purposes than aeration.

Hazardous and aggressive acid and caustic solution vapours can also be neutralized by a chemical gas absorber. Lime hydrate with colour indicator (BM1K) or activated carbon (BM2K) are used as desiccant. The desiccant cartridge should be exchanged at the intervals stated on the data sheet (see data carrier) .

ATTENTION

The filling speed must not exceed 1500l/h when a chemical gas absorber is used. Liquid must not enter the desiccant. The cartridge must be replaced if this has happened.

Dosing pump (Pos. 100)

The medium is dosed by an oscillating positive displacement pump mounted on the tank.

The conveying capacity of the dosing pump can be set at the manual stroke length adjustment.

Depending on the design of the dosing pump, an additional automatic dosing is possible via pulse or analogue signals.

The dosing pump can also be fitted with an integrated overflow valve. This valve protects the pump from overpressure. The medium is fed back in the tank when the overflow valve opens.

Assignment of the pumps to the tank please see Chapter „Technical data“ ..

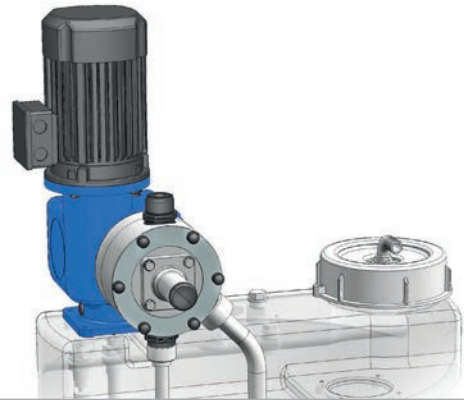

NOTE

Whether a pulsation damper must be installed or not, depends on the design of the overall system and must be determined from case to case.

Decisive factors are, among others, the pump size, the pipe geometry (length and diameter), pipe losses, the geodetic height to be negotiated and the opening pressure of injection fittings (which might be present) resulting from the spring load.

ATTENTION

If the dosing station is not fitted with a diaphragm overflow valve or a multifunction valve the owner of the system must ensure that the pump is protected against impermissible over pressure.

Multifunction valve (Pos. 150)

Dosing pumps with a conveying capacity up to 50 l/h can be supplemented with a multifunction valve. It protects the dosing pump against overpressure and serves as pressure keeping valve. It can however also be used for pressure relief of the pipe or for ventilation of the dosing pump. The medium is fed back in the tank via a return pipe.

Level indication (Pos. 200/220/240)

The level in the tank can also be detected by three magnetic float switches. Switching height (H) above tank bottom, see table:

Prealarm LSL (min. contact)						
Type	LSL level	H mm	Remaining volume in tank		Usable remaining volume in tank	
			L	%	L	%
CTD-40.1	FS1-300G.1	65	8,6	21,5	4,6	11,5
CTD-75.1	FS1-455G.1	85	13,5	18,0	8,0	10,7
CTD-100.1	FS1-600G.1	100	16	16,0	10,5	10,5
CTD-200.1	FS1-560G.1	98	33	16,5	20	10,0
CTD-300.1	FS1-820G.1	118	40	13,3	27	9,0
CTD-500.1	FS1-950G.1	136	64	12,8	47	9,4
CTD-1000.1	FS1-1000G.1	156	140	14,0	95	9,5

Dry-run protection of the pump LSL (min-min contact)					
Type	LSL level	H mm	Usable remaining volume in tank		
			L	%	
CTD-40.1	FS1-335G.1	30	4,0		10,0
CTD-75.1	FS1-505G.1	35	5,5		7,3
CTD-100.1	FS1-665G.1	35	5,5		5,5
CTD-200.1	FS1-620G.1	38	13		6,5
CTD-300.1	FS1-900G.1	38	13		4,3
CTD-500.1	FS1-1050G.1	36	17		3,4
CTD-1000.1	FS1-1105G.1	51	45		4,5

Full level indication LSH (max. contact) als filling-stop						
Type	LSH level	H mm	Remaining volume in tank		Usable remaining volume in tankn	
			L	%	L	%
CTD-40.1	FS1-80G.1	285	37,5	94,0	33,5	84,0
CTD-75.1	FS1-80G.1	460	73,2	97,5	67,7	90,2
CTD-100.1	FS1-80G.1	620	98,5	98,5	93,0	93,0
CTD-200.1	FS1-80G.1	578	196	98,0	183	91,5
CTD-300.1	FS1-80G.1	858	292	97,3	279	93,0
CTD-500.1	FS1-80G.1	1006	476	95,2	459	91,8
CTD-1000.1	FS1-80G.1	1121	1000	100	955	95,5

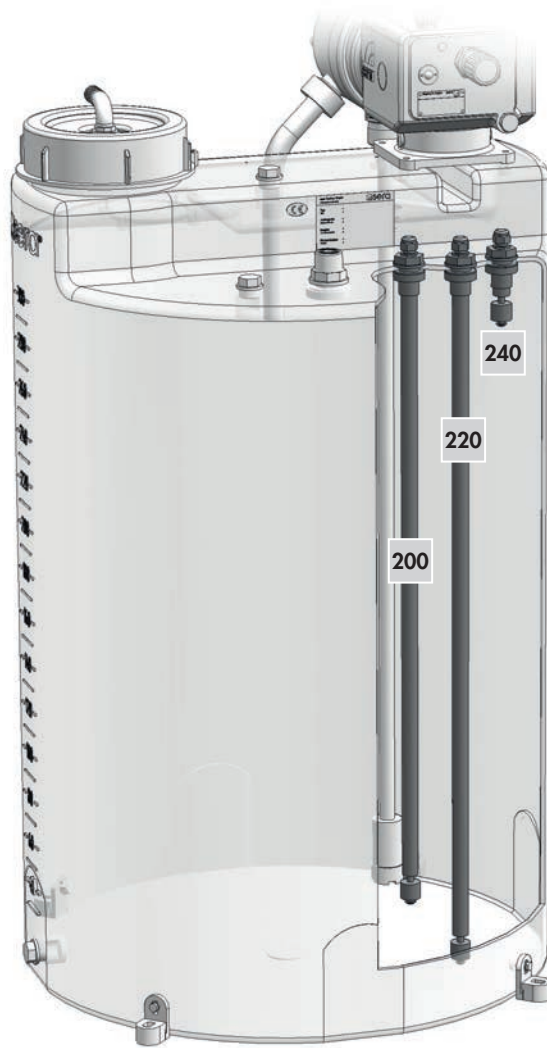

No.	Designation
200	Solenoid float switch, prealarm LSL (min)
220	Solenoid float switch, dry-run protection LSL (min-min)
240	Solenoid float switch, full level indication LSH (max)

i NOTE
 The solenoid float switches are not approved according to the Water Resources Act.

The signals are evaluated by the optional controller.
 The LSL and LSLL levels can also be evaluated directly at the pump if C-model pumps are used. The levels are connected to the pump via an M12 cable socket.
 If the levels are connected by the customer the data sheet of the solenoid float switches must be observed. An M12 cable socket can optionally be used as interchange point (for the pin assignment please refer to the wiring diagram CAE2091/CAE2096).
 Other switching heights (H) shall apply if a DN6 suction lance type SL11.1 or SL-12.1 with integrated solenoid float switches is used. Please see the dimensional drawing for this.

Filling valve (Pos. 300)

The filling line can be also connected via a ball valve with male thread (G1-DN15 or G1½ -DN25) and O-ring seal..



ATTENTION

Fill the tank only up to the level mark.
Overfilling might damage the dosing station.

Container threaded joint (Pos. 350)

The optional tank threaded joint can be used for an additional connecting pipe. The male thread G1-DN15 is fitted with an O-ring seal.

Drain cock or PE collecting basin (Pos. 400)

A DN15 ball cock can be used for emptying the tank.

If a drain cock is not used the dosing station can be placed in a collecting basin. The collecting basin is supplied as option.



ATTENTION

The angle brackets for floor mounting are not required if a collecting basin is installed.
The owner of the system must secure the dosing station against shifting and being overturned.



PRODUCT DESCRIPTION

Agitator (Pos. 500)

The tank can be equipped with a manually operated or an electrically driven agitator.

Agitators are used for mixing soluble media with each other.

The capacity of the electric agitators is designed for a maximum dynamic viscosity of 200mPas and a density of 1.2kg/dm³.

All electric agitators have a stabilizing ring allowing flow-through operation.

The electric agitator can be fitted with an integrated electronics system as option (EB-design, e.g. MU-200E 1500 EB.1). The electric agitator is then controlled directly at the control panel or by pulse or analogue signals.



Pos.	Designation	CTD-40.1	CTD-75.1	CTD-100.1	CTD-200.1	CTD-300.1	CTD-500.1	CTD-1000.1
1	Manual stamping mixer	✓	✓	✓	–	–	–	–
2	Manual agitator	–	–	–	✓	✓	✓	–
3	Electric agitator	–	–	✓	✓	✓	✓	✓



ATTENTION

The electric agitator operate only with closed screw cap!



ATTENTION

Do not reach into the tank when an electric agitator is in operation!

Level indicator for black tank (Pos. 600)

With black tanks the filling level is checked visually with a tube made of transparent PVC. The level indicator is fitted near the litre scale engraved in the tank.

Cabling (Pos. 700)

The CTD can also be equipped with a cabling as option. One side of the cabling is connected to the modules. The other side of the 5m/10m long cables has open cable ends for connection to a control cabinet or to the control system.

Control unit (Pos. 800)

The control unit of the dosing station controls the modules and evaluates the sensor signals. Please see the separate operating instructions for further details!

Accessories



WARNING

The operating instructions of the system components in the overall documentation must be observed!

CTD accessories	CTD-40.1	CTD-75.1	CTD-100.1	CTD-200.1	CTD-300.1	CTD-500.1	CTD-1000.1
Screw cap key lock	✓	✓	✓	✓	✓	✓	✓
Dissolving basket (not gas-tight)	–	✓	✓	✓	✓	✓	✓
Floor fastening for collecting basin (without mounting material) 3-4 pcs. required	✓	✓	✓	✓	✓	✓	✓
Splash guard (mounted onto the collecting basin)	–	✓	✓	✓	✓	–	–
PVC hose (transparent) d20 for connection of the ventilation system with hose clamp	✓	✓	✓	✓	✓	✓	✓
PVC hose (canvas) d30 for connection of the ventilation system with hose clamp	–	–	–	–	–	✓	✓
Terminal boxes and electrical connection sets	✓	✓	✓	✓	✓	✓	✓
Dosing equipment DE	✓	✓	✓	✓	✓	✓	✓

Dissolving basket (non gas-tight)

All compact tank dosing units which are not gastight can be upgraded with a dissolving basket (1). The basket will prevent the dissolved material from sedimentation at the tank bottom. The dissolving basket is made of black PE and is put into the tank opening below the screw cap (2).

Terminal boxes and electrical connection sets

Terminal boxes and electrical connection sets, see in the overall documentation.

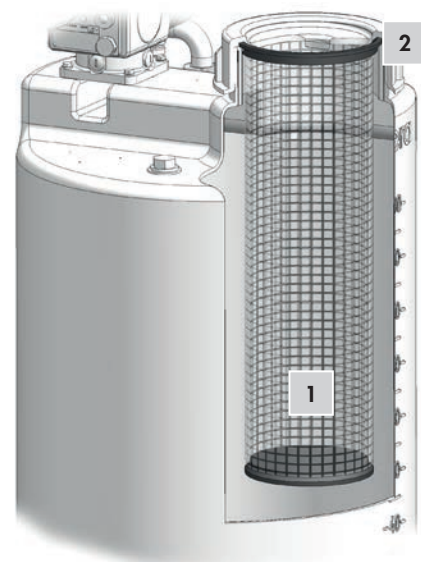

Splash guard

SFastening of splash guard with 2 wing screws
for CTD-75.1, CTD-100.1 and CTD-300.1



Fastening of splash guard with single-ended pipe clip on edge protection tube of the collecting for CTD-200.1

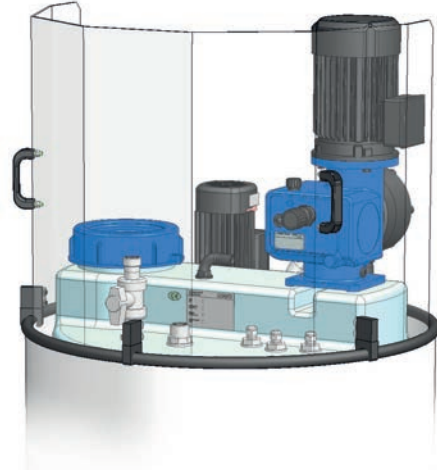

i NOTE

Splash guard can only be mounted together with a collecting basin.

Dosing equipment DE

The dosing equipment (type DE) comprises fittings on the pressure side for completion of a CTD (with dosing pump) Selection depends on the pump delivery rate. See dimension drawings see in the overall documentation .

The dosing equipment consists as standard:

- Diaphragm pressure keeping valve,
- Diaphragm pulsation damper and
- Stop valve as end fitting

	WALL MOUNTING	TANK MOUNTING			
	CTD-...	CTD-200.1	CTD-300.1	CTD-500.1	CTD-1000.1
DE-25.1	✓	✓	✓	✓	✓
DE-50.1	✓	✓	✓	✓	✓
DE-180.1	✓	✓	✓	✓	✓
DE-570.1	✓	✓	✓	-	✓

Tank mounting

The dosing equipment can also be mounted directly onto the tank in case of a CTD-200, CTD-300, CTD-500 or CTD-1000 if a hand agitator is not used on the CTD (electrical agitators are possible).

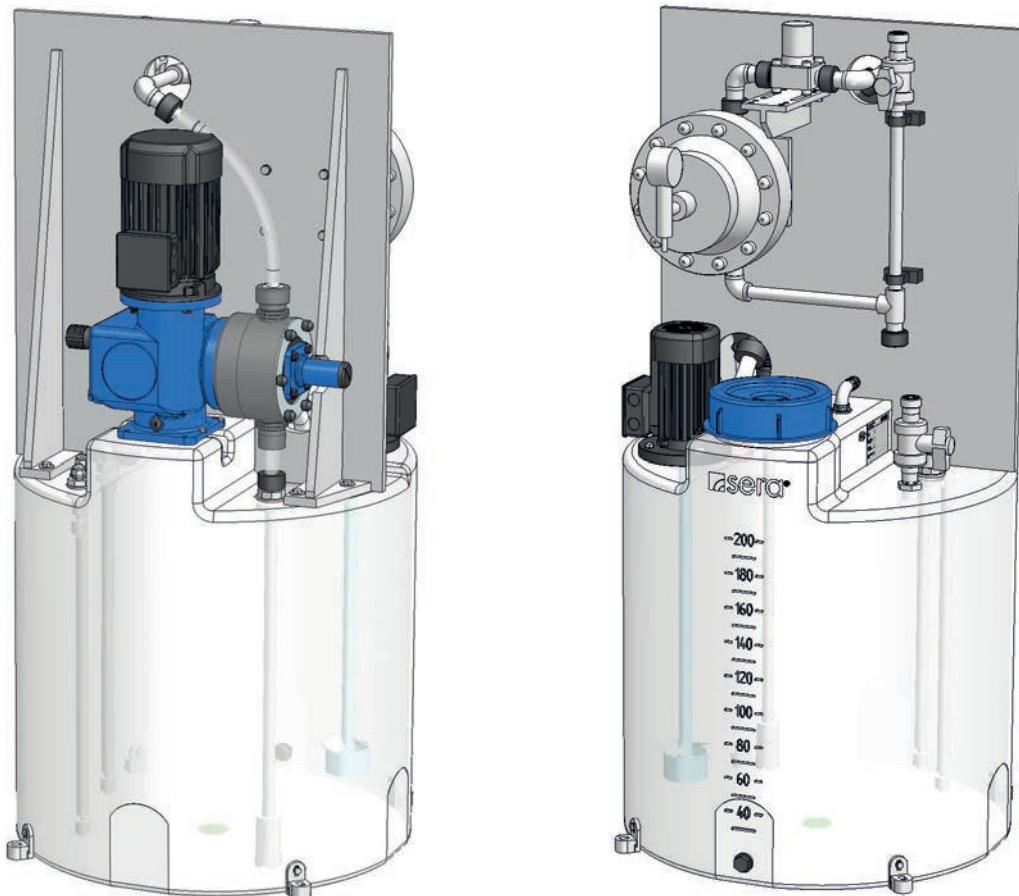

The dosing equipment will be mounted afterwards by the customer. The screws included in the scope of delivery should be used for fastening the dosing equipment on the tank. All versions can be fitted on the tank without impairing the gas tightness of the system.

Carry out the following steps:

- Loosen the optional return pipe for the CTD-200 and CTD-300.
- Have the fastening screws ready.
- Lift the mounting plate with two persons on the system and screw down in the threaded bushings provided therefor (in the pocket holes with the CTD-500).
- Lay hose straight or at a large radius to the pump pressure joint and cut to length.
- Clamp hose with threaded hose coupling.
- Fasten optional return pipe.
- Check threaded hose coupling for leaks and hose for damages.



ATTENTION

The hose must not be kinked! Hoses damaged by a kink must be replaced by all means!

PRODUCT DESCRIPTION

Wall mounting

For wall mounting the system can be fitted on a mounting plate which is attached near the CTD. 2m of connecting hose are included in the scope of delivery.

i NOTE

A dosing equipment for wall mounting must be used for a CTD with hand agitator and for all CTDs up to 100 l tank volume.



UNIT DATA		CTD - ...						
		.. 40.1	.. 75.1	.. 100.1	.. 200.1	.. 300.1	.. 500.1	.. 1000.1
Tank volume	Litres	40	75	100	200	300	500	1.000
Flow capacity	l/h	0,4...35	0,4...180	0,4...180	0,4...570	0,4...570	0,4...570	0,4...570
Permissible counterpressure	bar (max)	10	10	10	10	10	10	10
Nominal width of suction lance	DN	5	5/10	5/10	5/10/15	5/10/15	5/10/15	5/10/15

ASSIGNMENT OF PUMPS		CTD-40.1	CTD-75.1 ... CTD-1000.1
R204.1 - 1,2 e	...	R204.1 - 35e	■
C204.1 - 1,2 e	...	C204.1 - 35e	■
iSTEP S 20	...	iSTEP S 50	■
RF409.2 - 1,6e	...	RF409.2 - 350e	■
C409.2 - 1,6e	...	C409.2 - 350e	■
RF410.2 - 280e	...	RF410.2 - 570e	■
C410.2 - 280e	...	C410.2 - 570e	■
RF409.2 - 11 ML	...	RF409.2 - 220 ML	■
C409.2 - 11 ML	...	C409.2 - 220 ML	■
RF410.2 - 135 ML	...	RF410.2 - 500 ML	■
C410.2 - 135 ML	...	C410.2 - 500 ML	■

i NOTE

The performance and design data can be taken from the product description in the order confirmation.

NOISE MEASUREMENT

Max. sound pressure at max. burden 50 - 65 dB(A)

VISCOSITY

Viscosity of the pumped medium < 100mPas

TEMPERATURE DATA

Max. operating temperature 40 °C
 Min. operating temperature 0 °C
 Max. storage temperature 40 °C
 Min. storage temperature 0 °C

AMBIENT CONDITIONS

Max. installation altitude above sea level 1000 m
 Max. relative air humidity < 90%
 Max. relative air humidity during storage < 50%

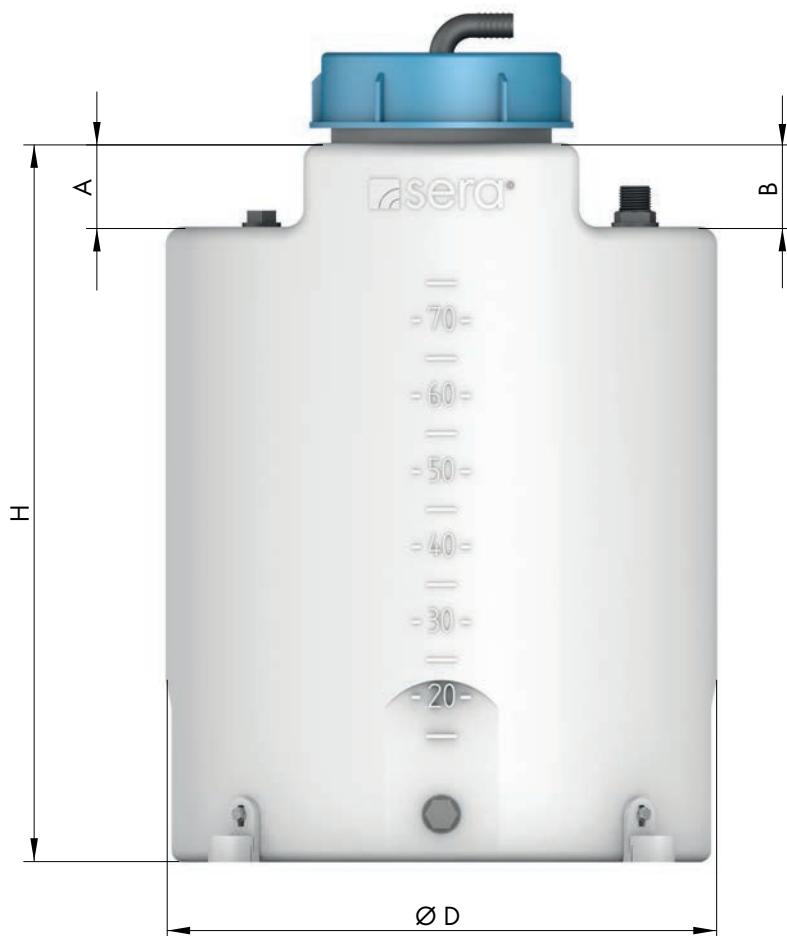

	CTD - ...						
	.. 40.1	.. 75.1	.. 100.1	.. 200.1	.. 300.1	.. 500.1	.. 1000.1
A	70	70	70	80	80	90	110
B	70	70	70	100	100	90	100
D	420	460	460	670	670	790	1080
H	425	600	760	750	1030	1170	1290

i NOTE

For the dimensions of the corresponding model please see the dimensional drawing in the overall documentation.

 **WARNING**

Observe and follow the safety instructions by all means.
See the additional instructions „SAFETY INSTRUCTIONS“.
Man, machine and environment are endangered if the safety instructions are not observed.

 **NOTE**

Design data of the system for the dosing medium and its temperature can be found in the order confirmation and/or the product description in the overall documentation.

 **NOTE**

Operating conditions:
Ambient temperature, relative air humidity and max. installation altitude ► see chapter „Technical data“.

- Check the complete dosing system for damage (e.g. transport damage).
- The system is designed for indoor installation and must be protected from direct sunlight.
- Build in the dosing system and attach it with appropriate material.
- The pipings on the suction and pressure side must be sufficiently dimensioned.
- Connect all pipes and make sure that they are tension- and vibration-free. An offset of the pipes within the area of the screwed and flanged connections must be avoided by all means.
- Connect the return pipe from the overflow valve so that a free and unhindered backflow of the medium is guaranteed (directly into the corresponding tank or using the option according to Chapter „Piping of the overflow valve“).
- Replace the transport closure (oil sight glass with seal) at the oil filler cap of the pump with the attached vent screw (observe the notes on the pump!).
- The electrical connections are to be made in accordance with the VDE (Association of German Electrotechnical Engineers) or the local electrical regulations applicable. See chapter „Electrical connection“.

 **ATTENTION**

If the dosing station is not fitted with a diaphragm overflow valve or a multifunction valve the owner of the system must ensure that the pump is protected against impermissible overpressure.

Place of installation

- The place of installation must be frost resisting and ventilated.
- An installation in an aggressive or explosion-hazardous area is not permitted.
- The installation data according to the Appendix must be regarded.
- The installation site must be equipped with proper lighting for all works to be carried out (installation, operation, maintenance etc.).
- Leaking chemicals must be disposed off in a safe and secure manner at the installation site.
- Protect against the direct irradiation of sun.
- Place the dosing station in such a way that operation and maintenance are possible at any time.

 **ATTENTION**

Pay attention to the safety data sheet of the pumped medium! The instructions in the safety data sheet regarding handling of the medium must be observed!



ATTENTION

The fastening material is not included in the scope of supply and must be provided by the customer depending on the condition of the wall!



ATTENTION

The mounting area must be flat.
Take appropriate measures in order to compensate for height differences so that the stand can be fastened without tension.

In the case of wall mounting, attach the system to the wall at a suitable height. Select the installation height so that operation and maintenance of the system are possible at any time. The position of the bore holes is shown in dimensions.



ATTENTION

Pay attention to the carrying capacity of the wall.
The wall must be flat so that the wall mounting plate can be fixed without tension.

Electrical connection

The electrical connection of the dosing station is to be made depending on the system design (please see the product description in the Appendix) and according to the operating instructions in the complete documentation



WARNING

Do not lay electric leads near the contact area of the chemicals (e.g. on the screw cap).



WARNING

The electrical connection must only be done by qualified personnel. The local safety regulations must be observed.



ATTENTION

The fuse protection and the characteristics of the electrical components are indicated in the separate manuals.



NOTE

Have the electrical installation checked by the responsible safety officer after the work was finished. Carry out an insulation measurement if necessary!

**WARNING**

Observe and follow the safety instructions by all means.
See the additional instructions „SAFETY INSTRUCTIONS“.
Man, machine and environment are endangered if the safety instructions are not observed.



Carry out the following steps to start the system:

- Before commissioning check all the pipe connections, screwed and flanged connections etc. for proper fit and retighten, if necessary.
- Before switching on the system for the first time, the following points should be checked:
 - Check the electrical connections and the terminal assignment.
 - Check the electrical excess-current cut-outs for proper operation and correct setting.
 - Check whether the local supply voltage and frequency correspond with the indications on the type plates.
 - Check the function of the system components (see overall documentation).
- Carry out the first startup with water. Note the water quality according to the chapter „Water quality“.
- Open all shut-off devices that are required for operation. Close the shut-off device for emptying the tank.
- Set the stroke adjustment and the stroke frequency adjustment (only for C-pumps) to values lower than 50% and start the pumps slowly.
- The integrated overflow valves and the multifunction valves are factory set to the maximum admissible operating pressure of the dosing pump (see product description).
- Have the pump deliver against operating pressure and check the piping for leakage.
- After startup drain the water completely from all the pipes and the pump.
- Empty the tank if necessary.
- Start the dosing system with the chemical reagent.
- Preload the pulsation damper to the pressure required for operation according to the separate technical manual. This corresponds normally to 50% of the operating pressure.

**ATTENTION**

Check whether the set pressure of the overflow valves must be reduced in relation to other system parts installed which may only be submitted to a lower load. Correct the settings according to the technical manual „Diaphragm relief valve“.



WARNING

Observe and follow the safety instructions by all means.
See the additional instructions „SAFETY INSTRUCTIONS“.
Man, machine and environment are endangered if the safety instructions are not observed.



All maintenance work is to be documented carefully.

All technical devices must be serviced in order to guarantee proper function of the dosing station. Generally valid statements cannot be made as the maintenance schedule depends on various factors.

- Regular maintenance of the system components according to separate instructions.
- Check the piping for tightness once a week, and repair, if necessary.
- Check the screwed connections for tightness every six months or before starting the system after a longer period of standstill.
- Check the system visually, and check the pressure every six months.
- Check the wires and electrical components for visual damage (loose connections, damaged cables, damaged devices etc.) every six months.
- Check the preload pressure of the pulsation damper (option) once a week according to the separate instructions and adjust, if necessary.
- The maintenance interval of the sieve at the foot valve of the suction lance depends on the degree of contamination of the medium and must be determined by the owner. The sieve must be cleaned at the latest when the conveying capacity decreases.
- Check the function of the level sensors every six months.
- Replace the desiccant of the chemical vapour lock at regular intervals according to the separate instructions.
- Service the electric agitator at regular intervals according to the separate instructions.



ATTENTION

Danger of burns!
The shaft of the electric agitator can be very hot near the flange.
Leave to cool before disassembly!



ATTENTION

Note the max. tightening torques of the threaded sockets on the tank:

- M6 - max. 3,5Nm
- M8 - max. 6Nm

These specifications apply for the pumps, mixing units and dosing equipment.

Wearing parts

sera recommends to maintain the dosing station twice a year to ensure proper operation.

Yearly maintenance comprises replacement of the gaskets that come into contact with the chemical, diaphragms (yearly or after 3,000 operating hours), suction and pressure valves of the dosing pumps. Please see also the separate instructions on the data carrier for maintenance of the parts.

Maintenance work which is carried out every six months comprises the checking of the complete dosing station:

- Check the overall function.
- Check the complete system for leakages.
- Function check of the level sensors.
- Function check pulsation damper according to separate instructions (Dosing equipment).
- Check the wires and electrical components for visual damage at regular intervals (loose connections, damaged cables, damaged devices etc.).
- Check the oil filling level of the dosing pumps.

**WARNING**

Observe and follow the safety instructions by all means.
See the additional instructions „SAFETY INSTRUCTIONS“.
Man, machine and environment are endangered if the safety instructions are not observed.

**Decommissioning**

The following points must be observed when you decommission the dosing station:

- Drain the chemical from all pipes and the tank or suck off.
- Rinse the pipes with water (see Chapter „Water quality“) or a suitable medium and empty the pipes afterwards.
- Set the stroke length of the pumps to 50% to remove load from the diaphragm.
- Reduce preload pressure of the pulsation damper (dosing equipment).
- Disconnect the dosing station from the power supply.

Disposal

- Shut-down the system. Please see “Decommissioning“.

Disassembly and transport

- Shut-down the system. Please see “Decommissioning“.
- Remove all fluid residues, clean thoroughly, neutralize and decontaminate.
- Package the dosing system appropriately and ship.
- If the system is shipped for repair the gearing must be filled with oil.

**NOTE**

A clearance certificate must be filled in when systems are returned to the manufacturer.
Acceptance will be rejected if this clearance certificate is not attached.

Complete disposal

- Remove all fluid residues from unit.
- Drain off lubricants and dispose of according to regulations!
- Dismount materials and send them to a suitable waste disposal company!

CLEARANCE CERTIFICATE

i NOTE

Inspection / repair of machines and machine parts is only carried out after the clearance certificate was filled in correctly and completely by authorized and qualified personnel.

i NOTE

Acceptance will be refused if parts are returned to the manufacturer without a proper clearance certificate.

All industrial companies are obligated by the legal provisions for occupational health, e.g. the workplaces ordinances, the Ordinance on Hazardous Substances, the regulations for prevention of accidents and the environmental protection regulations such as the Waste Management Act and the German Household Water Act to protect their employees or man and the environment from detrimental effects when handling hazardous substances.

Should special safety precautions be necessary despite careful draining and cleaning of the product the necessary information are to be provided.

Machines which are operated with radioactive media shall only be inspected and/or repaired in the safety area of the owner by a **sera** specialized fitter.

The clearance certificate is part of the inspection-/repair order.
sera reserves the right to refuse acceptance of the order for other reasons.

DOWNLOAD

Clearance certificate

Or directly scan the QR code opposite:



Clearance Certificate 

RECIPIENT

sera ProDos GmbH
Wareneingang z. Hd. Abt. Service
sera Straße 1
D-34376 Immenhausen/Hessen

SENDER

Company:	<input type="text"/>	Phone:	<input type="text"/>
Contact partner:	<input type="text"/>	Fax:	<input type="text"/>
Street address:	<input type="text"/>	E-Mail:	<input type="text"/>
Postcode, City:	<input type="text"/>	Your order number:	<input type="text"/>

We confirm that we have entered the information in this clearance certificate (decontamination certificate) correctly and completely and that the returned parts have been carefully cleaned.
The parts sent in are therefore free of residues in dangerous quantities.

<input type="text"/>	<input type="text"/>	<input type="text"/>
Place, Date	Department	Signature (and company stamp)

www.sera-web.com 

© 2019 sera GmbH. Alle Rechte vorbehalten. www.sera-web.com

FOLLOW US



sera GmbH

sera-Str. 1
34376 Immenhausen
Germany
Tel. +49 5673 999 00
Fax +49 5673 999 01
info@sera-web.com